

# INSTALLATION PLAN

FRONT

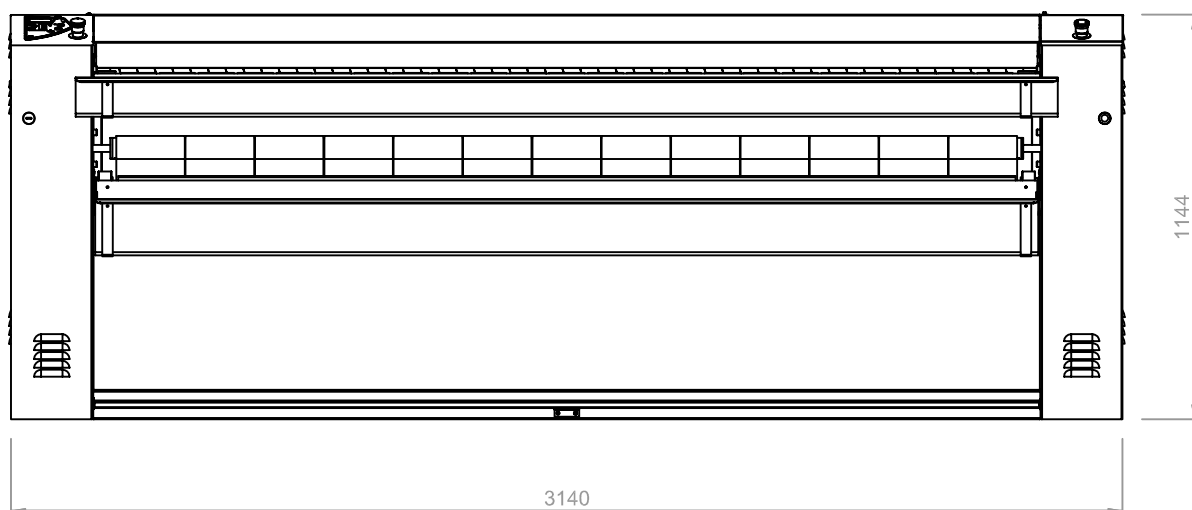

TOP

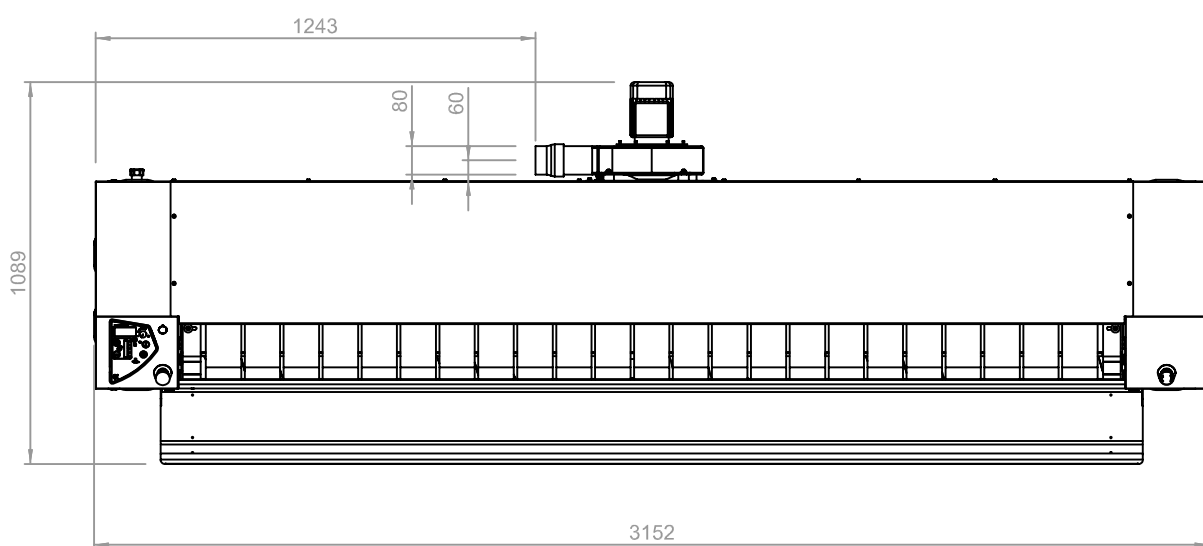

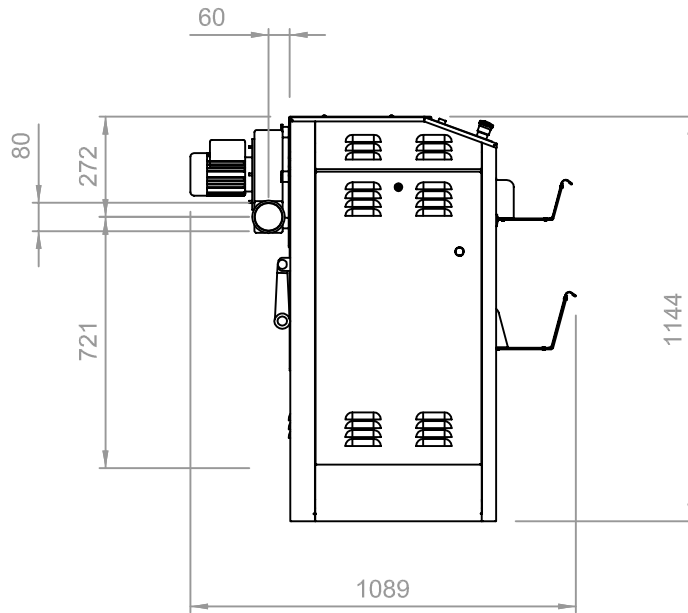

**INSTALLATION PLAN**

**SIDE**



**WHAT YOU NEED**

Electrical cable + industrial plug			
	V.230/1/50-60Hz	V.230/3/50-60Hz	V.400/3N/50-60Hz
	n/a	87,7 Amps	50,5 Amps
Total power required	n/a	34,9 kW	34,9 kW
Differential magnetothermal switch	n/a	Idn = 0.03 Amps	Idn = 0.03 Amps
Ducting	n/a	Ø80 mm, 280 m <sup>3</sup> /h	Ø80 mm, 280 m <sup>3</sup> /h
Clearance around the ironer	back: 500 mm - right: 500 mm - left: 500 mm		